



*An Online PDH Course  
brought to you by  
CEDengineering.com*

## **An Introduction to Sustainable Lighting Design**

Course No: E02-015

Credit: 2 PDH

---

J. Paul Guyer, P.E., R.A., Fellow ASCE, Fellow AEI

---



Continuing Education and Development, Inc.

P: (877) 322-5800

[info@cedengineering.com](mailto:info@cedengineering.com)

[www.cedengineering.com](http://www.cedengineering.com)

*This course is adapted from the Unified Facilities Criteria of the United States government, which is in the public domain, has unlimited distribution and is not copyrighted.*

## **CONTENTS**

- 1. SUSTAINABILITY ISSUES**
- 2. DAYLIGHTING**

## **1. SUSTAINABILITY ISSUES**

**1.1 INTRODUCTION.** Provide sustainable design to achieve the required LEED or other certification level in accordance with owner's objectives. Incorporating sustainable goals into the design process requires a careful analysis of both the cost and the benefits of the strategies outlined in the rating system. Any design strategy has both synergies and tradeoffs with other building systems and the project budget. Lighting design addresses several sustainable issues and presents multiple strategies that can be considered in a particular project: daylight utilization, lighting controls, energy efficiency, materials, light pollution, and light trespass. All of these issues have significant impacts on the project budget that can best be evaluated with a life-cycle cost analysis. Additionally, the most sustainable solution to a new building project may be to renovate an existing building. In this situation, certain lighting issues must be addressed to improve the efficiency and visibility of an existing system.

**1.2 BUILDING RATING SYSTEMS.** Because interpretations of sustainability vary dramatically, building rating systems serve as a defined baseline for and a means of comparison between building projects. Sustainable design inherently requires integrated design. Rating systems provide design and construction teams with a framework of sustainable and efficient strategies and the synergies and trade-offs that exist between them.

**1.2.1 THE US GREEN BUILDING COUNCIL, LEADERSHIP IN ENERGY AND ENVIRONMENTAL DESIGN (LEED™) RATING SYSTEM.** The LEED™ Version 2.2 rating system measures the "green" performance of new and existing commercial, institutional, and high-rise residential buildings. The system is divided into six categories: Sustainable Sites, Water Efficiency, Energy and Atmosphere, Materials and Resources, Indoor Environmental Quality, and Innovation and Design Process. Within each category, multiple credits can be obtained in addition to certain prerequisites that

must be met to qualify the project. All of the credits outline quantifiable and verifiable criteria. The lighting design for a project currently affects several credits and prerequisites: Sustainable Sites Credit 8, Light Pollution Reduction; Energy and Atmosphere Prerequisite 2, Minimum Energy Performance, Credit 1, Optimize Energy Performance; and Indoor Environmental Quality Credit 6, Controllability of Systems and Credit 8, Daylight and Views. Refer to the latest version of the LEED™ rating system for exact requirements.

**1.2.1.1 SUSTAINABLE SITES CREDIT 8, LIGHT POLLUTION REDUCTION.** This credit addresses exterior site lighting and its contribution to light pollution and potential for light trespass. These issues are addressed in “Sustainability Issues” along with strategies to minimize both.

**1.2.1.2 ENERGY AND ATMOSPHERE PREREQUISITE 2, MINIMUM ENERGY PERFORMANCE.** This prerequisite requires that the provisions of ASHRAE/IES 90.1 be met as a minimum baseline of building energy efficiency.

**1.2.1.3 ENERGY AND ATMOSPHERE CREDIT 1, OPTIMIZE ENERGY PERFORMANCE.** This credit addresses the overall building energy consumption. Because lighting can be a significant electrical load and also a cooling load on the HVAC system, reducing the lighting energy use minimizes the total building energy requirements. Strategies outlined in this UFC such as daylight integration, surface brightness, controls, and light source selection, all serve to reduce the energy used by the lighting system.

**1.2.1.4 INDOOR ENVIRONMENTAL QUALITY CREDIT 6, CONTROLLABILITY OF SYSTEMS.** Building occupants prefer to have control over their interior environment including the lighting system. This credit requires a certain degree of control per unit area of the lighting.

**1.2.1.5 INDOOR ENVIRONMENTAL QUALITY CREDIT 8, DAYLIGHT AND VIEWS.**

The controlled introduction of daylight into interior spaces reduces the lighting energy requirement and improves the comfort of the occupants. This credit outlines requirements for access to daylight and to view glazing within a space.

**1.2.1.6 FACILITY DELIVERY PROCESS, HOLISTIC DELIVERY OF FACILITY.** This credit requires that building systems (including lighting) be evaluated on a life cycle cost basis rather than first cost alone.

**1.2.1.7 CURRENT MISSION, OPERATION AND MAINTENANCE.** The lighting system must be included in the operation and maintenance program. Also, select lighting equipment that is appropriately durable and also makes sense with the life cycle cost analysis.

**1.2.1.8 OCCUPANT ACTIVITIES, PRODUCTIVITY AND RETENTION.** Many of the visibility issues including daylight, glare, and surface brightness all affect occupant comfort and productivity.

**1.2.1.9 FUTURE ACTIVITIES, FUNCTIONAL LIFE OF FACILITY AND SUPPORTING SYSTEMS.** Evaluate the expected life of lighting equipment and the cost of replacement in the building life cycle costs analysis.

**1.2.1.10 FUTURE ACTIVITIES, ADAPTATION, RENEWAL AND FUTURE USES.** Consider lighting system designs that are not dependent on current furniture layout and are flexible for changes in use. Task ambient lighting systems achieve this goal.

**1.3 COSTS / BENEFITS.** While the cost and benefit of any design strategy must be evaluated with respect to an individual project, some issues are common to the sustainable design of any facility.

**1.3.1 DAYLIGHTING.** Utilizing daylight to provide the light in the building has the benefit of reducing lighting energy requirements while improving the quality of the indoor spaces. However, it also requires a significant increase in design time and coordination between structural, mechanical, and electrical systems. This strategy may require additional modeling to ensure that daylight is provided without glare or increased heat gain. This results in increased design requirements. Additionally, facilities may require increase in the strength of glazing. Therefore, the addition of glazing may significantly increase the cost over a commercial building. However, worker productivity benefits may still outweigh these costs.

**1.3.2 CONTROLS.** Lighting controls have the benefit of reducing energy use when lighting is not required. However, the cost of the control device increases the initial system cost. For most applications, typical energy savings pay for control devices in approximately 3 to 7 years. The time period may be less when worker satisfaction is considered. This payback makes lighting control an attractive energy saving strategy. It is important to note that electric lighting controls must be incorporated with a daylight design to gain any energy savings from the daylight.

**1.3.3 ENERGY EFFICIENCY.** The careful selection of light sources to utilize the most efficient and lowest wattage light source for the application reduces energy use and cost. This results in a significant benefit with a low cost increase. The increase in light source cost between incandescent sources and more efficient, longer life, fluorescent sources is typically paid back in energy savings and replacement costs within a few years.

**1.3.4 MATERIALS.** The mercury content of fluorescent, induction and HID light sources poses an environmental threat when sent to a landfill or incinerator. By law, commercial and other facilities must recycle these light sources. This cost must be considered when developing a life-cycle cost analysis.

**1.3.5 LIGHT POLLUTION / LIGHT TRESPASS.** Light pollution and trespass are reduced with the selection and location of lighting equipment. The benefit of addressing this issue is increased visibility and a minimal impact on the night sky. There is not necessarily an associated increase in cost. Shielded luminaires are not necessarily more expensive than non-shielded luminaires. When considering glare and veiling luminance criteria in addition to illuminance or luminance criteria, more luminaires may not be necessary. Designing to minimize light pollution and trespass encourages minimizing the amount of equipment and avoiding overlighting exterior areas. Both of these aspects may reduce initial cost.

**1.4 UTILIZING DAYLIGHT.** The introduction and control of daylight into interior spaces has a twofold benefit. It can reduce the amount of energy that is necessary to light interior spaces and it also has a significant effect on the indoor environmental quality for the occupants.

**1.4.1 DAYLIGHT IS A RELIABLE AND EFFICIENT LIGHT SOURCE.** When properly controlled, it can provide quality and adequate light levels without becoming a source of glare or overheating a space. Architectural shading devices including overhangs and canopies can provide sufficient ambient light while eliminating direct glare. Strategies and technical details for successfully providing daylight to achieve these goals are discussed later.

**1.4.2 THE INTRODUCTION OF DAYLIGHT** into interior spaces has a well-documented effect on the productivity of occupants and the education of students. In a recent study, students who worked in daylighted classrooms reportedly progressed 26% faster on reading exams and 20% faster on math exams than students working in a classroom with less daylight. In another study, office workers were found to perform 10% to 25% better on tests of mental function when the best daylight views were available to them.



**1.4.3 DAYLIGHTING STRATEGIES** can be divided into passive or active systems. Passive systems such as overhangs are the most common and refer to the location, profile, orientation, and shading of glazing on a building. Optimizing these components results in a building that admits daylight without excessive heat gain or glare. Because all of the devices and components are stationary, these techniques are categorized as passive. In comparison, active daylighting systems have moving parts, typically to track the sun throughout the day. An example of an active system includes a skylight with a moving mirror that captures direct sunlight and redirects it through the skylight, into the building.

**1.5 LOW ENERGY USE.** Energy efficiency in buildings necessitates a holistic approach to the design of the building systems and the integration between systems. The American Society of Heating, Refrigeration, and Air-conditioning Engineers (ASHRAE) and the IES have produced ANSI/ASHRAE/IES 90.1. This document addresses efficiency standards that must be met for minimum energy performance.

**1.5.1 EFFICACY REFERS TO** the amount of light (lumens) that is produced by a light source for every watt of energy. Different light sources produce light at different efficacies. Incandescent light sources have the lowest efficacy while fluorescent, induction, and metal halide sources have highest efficacies. Efficacy must be considered along with the application to select the most efficacious source that will light the surface or task appropriately.

**1.5.2 EFFICACY IS OFTEN THE FOCUS** of energy efficiency in lighting systems. While this is important, it is not the only strategy for reducing energy consumption. As described in the Surface Brightness, Task, Ambient, and Controls sections of Lighting Design Considerations, what the lighting design illuminates, how it is layered into separate systems, and how it is controlled (in response to daylight and occupancy), all affect the energy consumption. Increasing surface brightness can reduce the amount of energy necessary to light a space. Dividing the lighting system into task and ambient

components allows the ambient system to use less lighting energy, and an increase in light levels is provided only where it is required: at the task, not throughout the entire space. By controlling these lighting components separately, only the energy that is required at any given time is consumed.

## **1.6 MATERIAL ISSUES.**

**1.6.1 MERCURY CONTENT.** Fluorescent, metal halide, induction and high-pressure sodium light sources contain liquid mercury to produce the mercury vapor necessary for operation. When light sources are broken or incinerated the mercury may be released into the soil or the atmosphere. Mercury has been linked to potential health risks. Some light source manufacturers offer product series that feature reduced mercury content.

**1.6.2 RECYCLING.** Traditional light source types except incandescent sources contain some level of mercury. These light sources should be recycled to avoid release of any mercury into landfills. The cost of recycling light sources should be included in any life-cycle cost analysis.

**1.6.3 LIGHT SOURCE LIFE.** The life expectancy data given by light source manufacturers refers to the approximate time at which 50% of the light sources in a group are no longer operating, except for LED which is the operating time over which the LED light source will maintain 70% (L70) of its initial light output. The life of standard incandescent and tungsten halogen sources can be extended by dimming them 5% to 10%. Frequent switching of fluorescent sources can reduce the light source life. However, the use of rapid start or programmed ballasts reduces the impact of frequent starting on the light source life. Recent developments in light source technology have introduced long life light sources that have four to five times the life of standard incandescent light sources. Examples include SSL and induction light sources with useable lives of 50,000 to 70,000 hours.

**1.7 LIGHT POLLUTION.** Light pollution or sky glow is caused by light aimed directly up into the sky and by light reflected off the ground or objects. Sky glow prevents the general public and astronomers from seeing the stars. Floodlights, wall packs and other un-shielded luminaires are the major contributors to sky glow. Overlighting, even with shielded luminaires, reflects unnecessary light back into the atmosphere and adds to the sky glow. This often occurs at outdoor areas such as motor pools and sports fields.

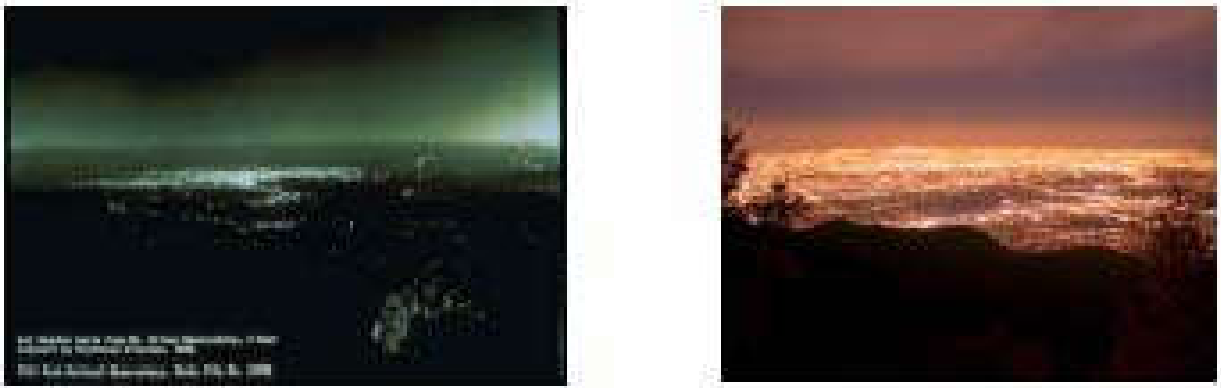

Figure 1

Los Angeles, 1908 (left), Los Angeles, 2002 (right).



Figure 2

Unshielded and non-cutoff luminaires lead to light pollution

**1.7.1 TO MINIMIZE LIGHT POLLUTION,** use fully shielded luminaires for area and roadway lighting as illustrated in Figure 3. The use of full cutoff (fully shielded) luminaires may reduce uniformity and therefore require greater pole heights or spacing.

Unshielded luminaires may also be used at low mounting heights if the lumen output of the light source is limited to 4200 lumens. These applications, such as pedestrian and entry lighting, typically require greater vertical illuminance for facial identity. Provide uniform low glare lighting and do not overlight exterior areas. Also, control lighting with time clocks, photocells, and motion sensors such that lighting is only energized when needed.

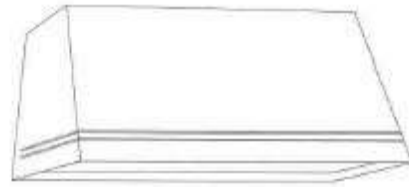

Figure 3

Examples of IES fully shielded luminaires

**1.8 LIGHT TRESPASS.** Light trespass is referred to as nuisance glare or the “light shining in my window” effect. It is usually caused by a glare source that is bright compared to the darker night surround. Since glare inhibits our ability to “see” tasks and decreases contrast, all designs must minimize glare.

**1.8.1 UNCONTROLLED LIGHT SOURCES (FLOODLIGHTS)** are usually the cause of light trespass. Not only does light trespass cause neighbor annoyance, but it also increases light pollution.



Figure 4

Glare results in loss of visibility

**1.8.1.1 TO MINIMIZE LIGHT TRESPASS**, use only fully shielded luminaires for area lighting. When unshielded luminaires such as wall packs and decorative luminaires are used at low mounting heights, reduce the light source brightness to that of a 4200 lumen light source (similar to a 55 watt induction light source) or less. Do not overlight areas because reflected light can also result in complaints and poor visibility by increasing visual adaptation. Also, consider dimming or turning lighting off when not needed and activate with motion sensors or timers when activity occurs.



Figure 5

Fully shielded or IES fully shielded luminaires (left) are recommended.  
Do not use unshielded floodlights (right).

**1.8.1.2 LEED CREDIT FOR LIGHT TRESPASS.** When pursuing the LEED credit for light pollution and light trespass, designers must consider the multiple-building environment of many installations. The credit limits the amount of light trespass on adjacent properties. However, in many cases, spill light from one project may be desired to light another area. Adjacent projects may all have the same owner. The credit calls for control of interior lighting during night time hours to prevent light from trespassing to exterior areas. Automatic lighting controls that turn lights OFF or to low dimmed levels during night time hours, such as occupancy sensors or time clocks, should be used to perform this function. Furthermore, automated window shades or dynamic glazing systems can be used on the windows to prevent light from escaping during night time hours. See the *LEED Application Guide for Multiple Buildings and On-Campus Building Projects* for guidance and more information.

**1.9 ECONOMIC ISSUES.** The economic benefits of sustainable building strategies may not be immediately obvious until a life cycle cost estimate is evaluated. Various methods and programs can provide a life cycle cost for different building systems. The Federal Energy Management Program (FEMP) provides technical assistance for these methods.

**1.9.1 SOME STRATEGIES REQUIRE NO ADDITIONAL INITIAL COST.** Others may require a higher initial cost, but will often payback that cost increase within a few years. Some initial costs may provide for savings in other systems resulting in no net increase in the overall building cost. For example, skylights, shading devices, and lighting controls may increase the cost of the lighting and glazing systems, but it may result in a downsizing of the mechanical system and mechanical space required.

**1.9.2 NOT ALL ECONOMIC ISSUES** are included in a life cycle cost. For example, the economic benefits of improved productivity in more comfortable daylighted buildings are not easily quantified. Additionally, energy efficiency reduces energy costs but also avoids the cost of externalities of energy production. Externalities are costs of energy

production that are not included in the cost of the energy. Such externalities include costs of cleaning up pollution generated by a coal mine and a coal fired power plant. Other examples may include healthcare costs resulting from pollution-related illnesses.

## **1.10 RETROFITTING.**

**1.10.1 MANY EXISTING LIGHTING SYSTEMS** can be replaced with new technology to provide appropriate lighting. Consider luminaires in good condition, whether relocated or salvaged, as an alternative to new lighting equipment when replaced with efficient technology. This may be a more cost effective solution to energy efficiency than new construction. In other situations however, a redesign may be more appropriate than a simple replacement of existing equipment. For example, closely spaced luminaires may be providing an unnecessary amount of uniformity or an excessive lighting level. A full redesign that provides an ambient light level as well as a higher task light level may prove to be the most cost effective solution over the life cycle of the building. Replacement requires appropriate design analysis to ensure that acceptable results will be achieved. Redistribution of light should only be accomplished based upon sound design principles. Specular reflectors and parabolic retrofits should only be used after testing and system design is accomplished. The following paragraphs provide typical replacement possibilities; however, it is stressed that lighting design changes require proper evaluation on a case-by-case basis.

## **1.10.2 EXISTING TROFFER SYSTEMS.**

**1.10.2.1 TYPICAL INSTALLATIONS.** Convert T-12 lighting systems to T-8 light sources and electronic high frequency ballasts. In most cases, de-lamp 4-lamp luminaires may be converted to either 2- or 3-lamp. White painted reflectors should be installed in older parabolic troffers. Install new lenses in lensed troffers if existing lenses are more than 7 years old.

**1.10.2.2 T-12 FLUORESCENT LIGHT SOURCES** come in a nominal 4 ft (1.2 m) length and are therefore suitable for retrofit with T-8 light sources. T5 and T5HO light sources are a metric length and slightly shorter than T-12 and T-8 light sources. These light sources cannot be supplied in place of the 4 ft (1.2 m) light sources and also may not be an appropriate brightness. Luminaires need to be specifically designed for use with T5 and T5HO light sources to control the brightness.

**1.10.2.3 SPECIFIC LIGHT SOURCE AND BALLAST COMBINATIONS** offer greater light output, extended life, or energy savings. They may be especially beneficial in retrofit applications to reduce the number of light sources or achieve energy savings.

**1.10.2.4 SPECIAL CONSIDERATIONS FOR COMPUTER INTENSIVE WORKSPACE.** Most lensed troffers are not suited for computer workspaces. Consider relighting with a direct/indirect or semi-indirect pendant system.

### **1.10.3 EXISTING DOWNLIGHTS.**

**1.10.3.1 TYPICAL INSTALLATIONS.** Remove the incandescent light source and socket, and install a hardwired compact fluorescent adapter using a standard plug-based compact fluorescent light (CFL) source. It is important to consider the base orientation for CFL sources as some may not be suitable for all orientations and source life may be compromised. In many cases, replacement of the reflector is also required to efficiently utilize the compact fluorescent light source. Compact fluorescent light source watts should be about 25 percent to 30 percent less than original incandescent light source watts to achieve similar light levels. Some of these sources can be dimmed when using a dimmable ballast in the luminaire.

**1.10.3.2 A TYPICAL INSTALLATIONS.** In some cases, hardwired conversions can be difficult or not cost effective. Use a medium based adapter with an integral ballast and replaceable compact fluorescent light source. Compact fluorescent light source watts



should be about 25 percent to 30 percent of less than original incandescent light source watts to achieve similar light levels. Some of these light sources can be dimmed. However, not all compact fluorescent or LED medium base light sources can be used with the base up or in a recessed housing. Check specifications for allowable applications.

**1.10.3.3 LED RETROFITS.** LED components are now available for downlight replacements. As of this writing, very few acceptable A-lamp style LEDs are on the market. While this will certainly improve, be sure to consider equivalent lumen output, light source life, cost effectiveness, light source orientation (can it be installed with the base up) and light source enclosure (can it be installed in an enclosed housing). Other LED modules are available that replace the entire light source and reflector portion of the downlight. Additionally, few LED downlights come with an insulation contact (IC) rating. While these may provide some energy savings over incandescent, confirm the energy savings and cost effectiveness over fluorescent light sources. In some applications, LED may not be more efficient or cost effective than the established technologies. /2/ LED retrofits are only approved for replacement of CFL or incandescent sources (A lamp replacements) with Edison bases. At this time, LED retrofits are not approved for HID luminaires.

#### **1.10.4 EXISTING FLUORESCENT INDUSTRIAL LUMINAIRES, WRAPAROUNDS, AND STRIP LIGHTS.**

**1.10.4.1 REPLACE** F40T12 and F48T12 light sources and magnetic ballasts with T-8 light sources and electronic high frequency program start ballasts.

**1.10.4.2 FOR LIGHTING SYSTEMS EMPLOYING** F96T12 slimline and F96T12/HO light sources, consider all of the following:

- Retrofitting with electronic high frequency ballasts and continuing to use existing light sources
- Replacing 2.4 m (8 ft) light sources with 1.2 m (4 ft) T-8 light sources, possibly including high light output ballasts and high output T-8 light sources when replacing T12/HO light sources.
- Replacing 2.4 m (8 ft) light sources with T-8 2.4 m (8 ft) light sources and electronic high frequency ballasts.

**1.10.5 MAINTAINING UNIFORMITY.** Carefully consider changes in lighting systems and furniture systems so that lighting uniformity is not compromised. A lighting system that provides uniform illuminance on the work-plane in one furniture configuration may not provide the same uniformity in a different configuration.

**1.10.5.1 IN THE CASE SHOWN,** an additional luminaire is required to adequately light the center workstation. This increases the amount of energy required to light the same area. In such a condition, the use of a semi-indirect, pendant system will provide better uniformity and at the same time allow for flexibility in the workstation layout.

#### **1.10.6 LOW CEILING APPLICATIONS.**

**1.10.6.1 IN SOME APPLICATIONS,** the ceiling height may be low and cannot be increased to accommodate pendant mounted lighting equipment. In these cases, the lighting design should still try to address the issue of surface brightness. One way to achieve surface brightness with low ceiling conditions is with recessed downlight/wallwash luminaires. The reflector on these luminaires looks similar to a standard downlight, but also uses a modification to light adjacent walls evenly. It is also designed to put light high on the wall next to the ceiling.

**1.10.6.2 INDIRECT LIGHTING** provides better visibility for offices and computer tasks than parabolic luminaires. Additionally, the installation cost of pendants can be lower than recessed troffer luminaires due to the reduced number of connection points. In low ceiling applications where a semi-indirect pendant system is not feasible, consider semi-specular parabolic troffers for lighting the interior of the space. Downlight wallwashers around the perimeter of the space increase the surface brightness of the walls. This strategy is a better choice to eliminate glare than the use of lensed troffers. However, avoid shallow troffers designed to spread the light. These achieve wide distributions by lowering the light sources in the luminaire and thereby increasing the glare.

**1.10.6.3 SEMI-INDIRECT PENDANT** manufacturers offer short pendant luminaires for low ceiling applications. These luminaires use refined optics to spread the light out and light the ceiling with a pendant length of under 0.3 m (12 in). These luminaires allow semi-indirect lighting systems in spaces with a ceiling height of 2.4 m (8 ft).

### **1.10.7 EXISTING HID, FLOODLIGHTS, DOWNLIGHTS AND OTHER LUMINAIRES.**

**1.10.7.1 REPLACE MERCURY VAPOR LIGHTING** systems with one of the following approaches:

- Replace mercury vapor light sources with compatible metal halide or induction light sources, especially if increased light levels are required.
- For interior high bay applications, replace with a linear fluorescent or induction system. This replacement is especially appropriate for applications where switching or dimming could be encouraged to save energy in addition to improving visibility. Fluorescent retrofits are not a one-for-one replacement of HID luminaires but rather an alternate lighting system.

### **1.10.8 EXISTING EXIT SIGNS.**

**1.10.8.1 INCANDESCENT EXIT SIGNS** should be retrofitted with LED exit signs. Because of 1996 revised UL listing requirements for exit signs, consider replacing exit signs with all new LED signs.

### **1.10.9 EXISTING EXTERIOR.**

**1.10.9.1 EVALUATE EACH APPLICATION** to determine which broad spectrum technology (induction or SSL) suits the application and local environment conditions. SSL or induction should not be considered as a “one size fits all” solution.

**1.10.9.2 DESIGN REPLACEMENT SYSTEMS** to minimize overall energy consumption, reduce maintenance costs, illuminate areas to the appropriate levels, improve uniformity, reduce light trespass/light pollution, and improve the night time visibility. Simple retrofit projects will only yield minimum benefit.

**1.10.9.3 RETROFIT CONVERSION LED LIGHT SOURCES** or LED lighting modules that have been designed and constructed to be installed in existing high-intensity discharge (HID), mercury vapor, or fluorescent luminaire enclosures are prohibited.

**1.10.9.4 LED COMPONENTS AND LUMINAIRES** are being marketed for a wide range of retrofit applications. While the technology is improving rapidly and the cost is decreasing, it is imperative to evaluate the life cycle cost of any proposed retrofit. Most cost effective retrofit applications include areas where the long life of LED can reduce future maintenance costs. These include difficult to access cove lighting (such as high ceiling lobbies). Replacing compact fluorescent downlights with LED is not usually cost effective. It is also important to bear in mind heat management, photometric requirements, and ambient temperatures when considering LED retrofits.

### **1.10.10 LIGHTING CONTROL SYSTEM REPLACEMENT.**

**1.10.10.1 WHEN DEVELOPING A LIGHTING REPLACEMENT PROJECT** consider lighting controls to improve the energy efficiency of the space. Use the installed cost of the system when analyzing the lifecycle cost for a lighting replacement with controls. When possible integrate the lighting control system directly into the HVAC system to provide reduced HVAC load requirements and improve the buildings energy efficiency.

**10.10.2 WIRELESS LIGHTING CONTROL OPTIONS** should be considered for lighting replacement projects (easy installation, lower installed cost, no power packs necessary). Wireless products include; but not are limited to, occupancy/vacancy sensors, daylight sensors, plug-in switching modules, plug-in dimming modules, and personal controls.

## 2. DAYLIGHTING

**2.1 BENEFITS OF DAYLIGHT.** Daylight in interior spaces has multiple benefits. Daylighted environments provide a connection to the outdoors, are healthier for occupants and have the potential to save energy. Research has shown that children learn better, retail stores sell more product, and office workers are more productive in daylighted environments. Since daylight also helps to regulate our circadian cycle, introducing daylight into interior spaces is a top priority. Daylight is a natural resource that is more efficient than electric light and should be utilized to its fullest potential. Achieve a minimum of daylight factor of 2 percent (excluding all direct sunlight penetration) in 75 percent of all spaces occupied for critical visual tasks. See:

- The Heschong Mahone Group, “Daylighting in Schools”, <http://www.h-m-g.com/projects/daylighting/summaries%20on%20daylighting.htm>
- The Heschong Mahone Group, “Skylighting and Retail Sales”, <http://www.h-m-g.com/projects/daylighting/summaries%20on%20daylighting.htm#Skylighting> and Retail Sales - PG&E 1999
- California Energy Commission. (2003). *Windows and Offices: A study of office worker performance and the indoor environment* (Catalogue No. P500-03-082-A-9).
- “Design Objectives, Productive”, *Whole Building Design Guide*, 22 August 2002 <http://www.wbdg.org/design/productive.php>
- New Buildings Institute, Inc. “Lighting and Human Performance”, *Advanced Lighting Guidelines*, Chapter 2. 2001 Edition, p.2-12-13

**2.2 PROJECT TYPES THAT BENEFIT FROM DAYLIGHT.** The introduction of daylight into any space has the potential to provide these benefits for the occupants as well as reduce building energy use. However, some project types are better suited than others to take advantage of daylight.

**2.2.1** Open spaces with high ceilings such as hangars, warehouses, recreation centers, and maintenance areas offer good opportunities for toplighting with skylights and clerestories.

**2.2.2** Perimeter spaces such as offices, lobbies, classrooms, cafeterias, and residential areas are all good sidelighting applications.

**2.3 DAYLIGHTING ECONOMICS.** The use of daylight can produce more comfortable work environments. This benefit may be difficult to quantify, but the energy saved by dimming or switching electric light in response to daylight can be quantified. The implementation of skylights and clerestories as well as lighting control equipment such as dimming ballasts and photocells all increase initial cost. Therefore, the addition of glazing may increase the cost over a commercial building. Careful analysis must consider these costs to determine the payback of daylighting strategies. The following case studies describe projects where daylighting strategies and energy efficient lighting and controls have been added to an existing building. See:

- “Philip Burton Federal Building”, *Pacific Gas and Electric Company*, Daylighting Initiative, 1999.
- Rubinstein, Francis; Jennings, Judith; Avery, Douglas; “Preliminary Results from an Advanced Lighting Controls Testbed”, Ernest Orlando Lawrence Berkeley National Laboratory, Berkeley, CA, March 1998  
<http://eetd.lbl.gov/btp/papers/41633.pdf>
- “California State Automobile Association Office”, *Pacific Gas and Electric Company*, Daylighting Initiative, 1999.

- New Buildings Institute, Inc. "Lighting Controls", *Advanced Lighting Guidelines*, Chapter 8. 2001 Edition, p. 8-1

**2.3.1 FEDERAL BUILDING.** This lighting control retrofit project incorporated advanced lighting controls and daylight sensors for 16,720 m<sup>2</sup> (180,000 square feet). When adequate daylight entered the space, unnecessary lighting was turned off. Energy savings ranged from 30% to 41% for zones of luminaires nearest the windows and 16% to 22% for interior zones of luminaires. Using this type of control equipment, the payback for equipment ranges from 4.7 to 6.4 years.

**2.3.2 CALIFORNIA STATE AUTOMOBILE ASSOCIATION.** In this renovation, skylights with automatic louvers control the amount of light entering the building based on the amount of available daylight. Barometric exhaust vents in these skylights release heat gain from the skylight wells. Dimmable electronic ballasts raise and lower the electric lighting based on the amount of light in the space. High performance windows and manual shades were also utilized. Overall lighting energy use was reduced by 32% with these strategies.

**2.4 SYSTEM INTEGRATION.** If the majority of areas are daylighted, then the electric lighting becomes supplemental during daytime periods. Since our appetite for light is less in the evening and nighttime hours, daylighting does not need to be duplicated with electric lighting. Design electric lighting to supplement the daylighting. For example, when daylight is plentiful, the electric lighting must be dimmed near the daylight source. In other areas where the daylight penetration is not as great, the electric lighting can be increased. Electric lighting controls (daylight, occupancy, and vacancy sensors) can typically save up to 50% of the lighting energy in existing buildings and up to 35% in new buildings.



## **2.4.1 REQUIREMENTS FOR SYSTEM INTEGRATION.**

**2.4.1.1 CONTROL THE ELECTRIC LIGHTING** in response to the daylight by dimming it in task oriented areas such as offices, conference rooms, classrooms or turning it off in non-task areas such as circulation and lounge areas.

**2.4.1.2 DO NOT ATTEMPT TO** duplicate daylight with electric light – supplement it.

**2.4.1.3. COMMISSION CONTROLS** to maximize and tune energy benefit.

**2.5 MAXIMIZE DAYLIGHT POTENTIAL.** Building orientation, views, side and top lighting, shading devices, and selective glazing are all critical to maximizing daylight potential. All of the following recommendations are for the northern hemisphere. In the southern hemisphere, recommendations regarding north and south orientations are reversed. Also, interior spaces should have high ceilings and light reflective surfaces to allow deep daylight penetration. Provide architectural and shading devices for daylight and view windows. In areas of high threat, lightshelves tend to be discouraged because of blast mitigation. These objects can become additional projectiles during a blast. Refer to the Whole Building Design Guide, *Balancing Security/Safety with Sustainability Objectives*, [http://www.wbdg.org/resources/balancing\\_objectives.php](http://www.wbdg.org/resources/balancing_objectives.php).

**2.5.1 OVER 60%** of existing square footage of interior spaces (within the US) has access to roofs for top-lighting and 25% of existing national square footage has access to side-lighting. See Hescong, Lisa, “Daylighting Workshop”, Pacific Energy Center, (March 2003).

**2.5.2 BUILDING SHAPE.** The building shape and massing has a significant impact on how much daylight can reach the occupied spaces and therefore, how well various daylighting strategies will work in the building. Deep floor plates create dark interior spaces that will necessitate electric lighting even during the day. Narrower plates allow

daylight penetration throughout the entire building section. See Figure 6 for the effects of building shape and massing on daylight availability.

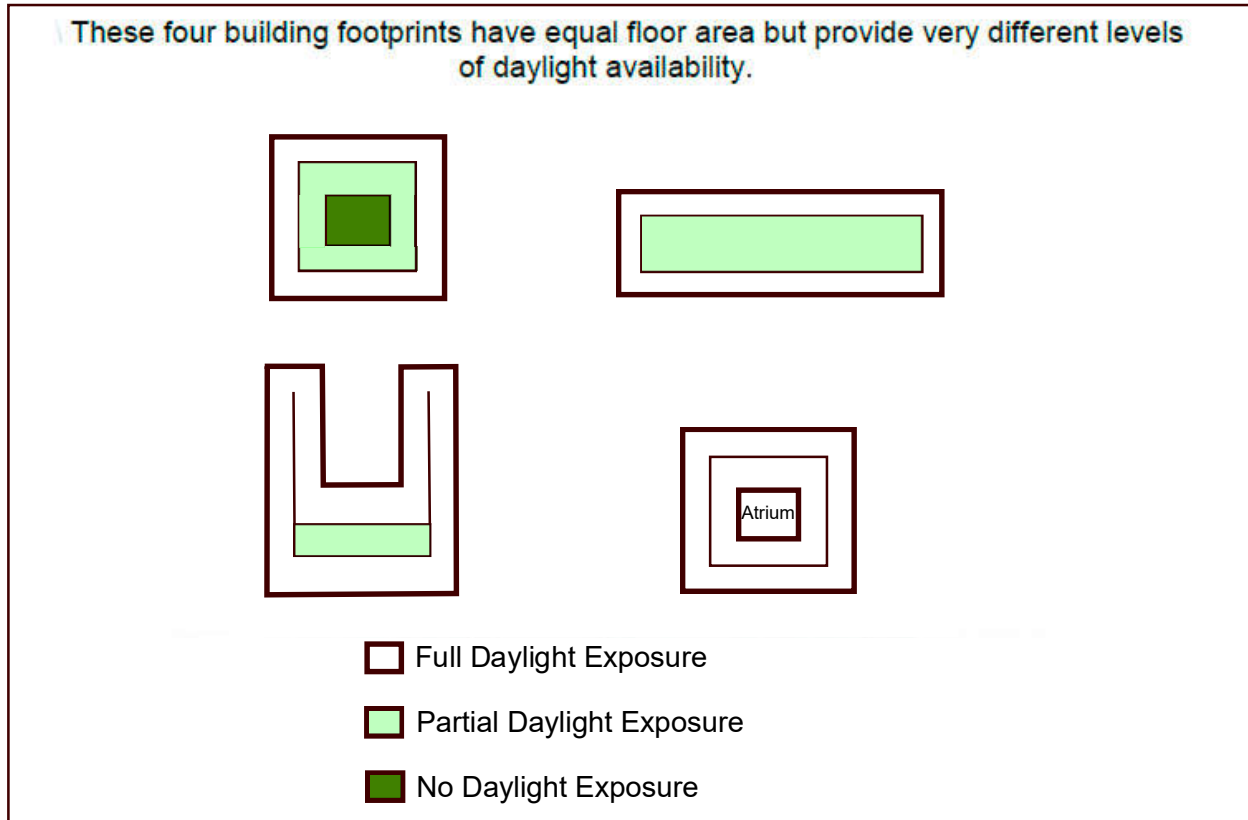

Figure 6

Effects of building massing on daylight availability.

### 2.5.3 CONSIDERATIONS TO MAXIMIZE DAYLIGHT POTENTIAL:

- Use the building shape to access daylight.
- Maximize view windows on the north and south facades.
- Provide high ceilings to allow deeper daylight penetration.
- Bring daylight high into the space to maximize penetration.
- Where possible, consider external light shelves to provide shading for view windows.

- Where possible, consider internal light shelves to provide shading for clerestories and also a surface for reflecting light onto the ceiling.
- Provide separate shading devices for daylight windows and view windows.
- Utilize selective glazing to maximize visible transmittance (high  $T_{vis}$ ) and minimize solar radiation (low shading coefficient).
- Use high reflectance values on ceiling and wall surfaces to balance out the daylight.
- Avoid daylight barriers such as solid walls near the building perimeter.
- Use clerestory and transom glazing to share daylight from perimeter windows to interior spaces.

**2.6 GLAZING ORIENTATION.** Building orientation is critical to maximizing daylight potential. Building orientations that maximize north and south exposures provide the most effective orientations while east and west exposures may allow excessive heat gain and are hard to control direct sun penetration. Southern exposures have the potential of providing over 50% of the daylight for the building space. The success to daylighting on southern exposures is controlling the direct sunlight penetration with shading devices. Northern exposures require minimal shading in the winter months. East and West orientations require manual shading devices. Vertical blinds control daylight well on this orientation.

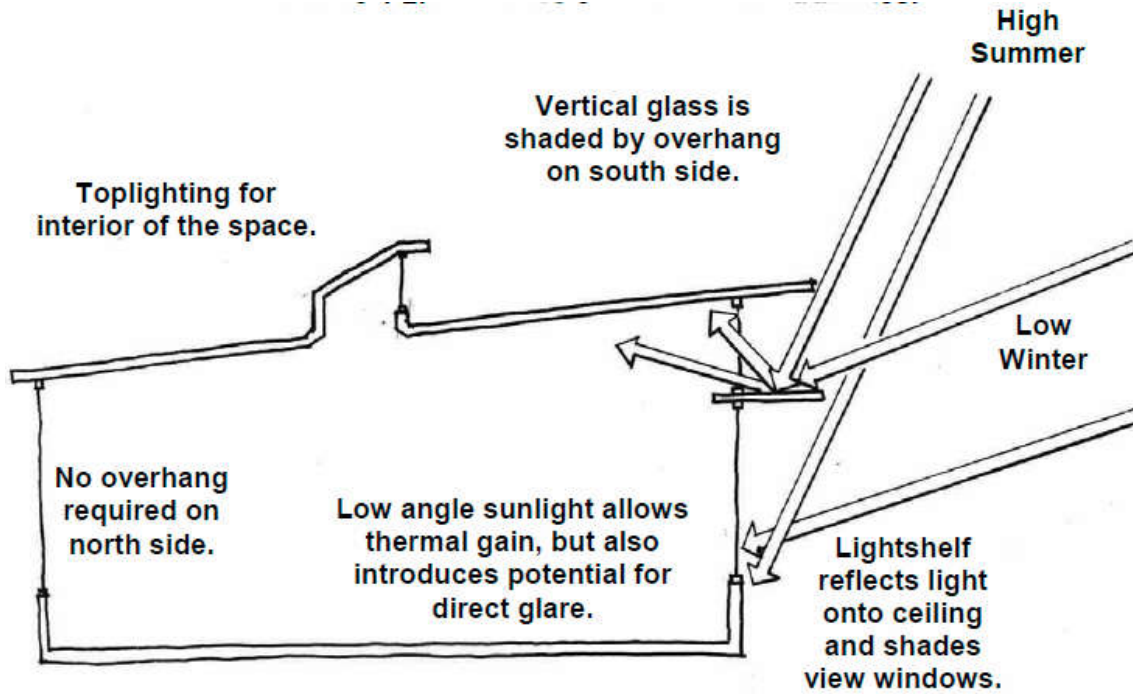

Figure 7  
Examples of Daylighting Strategies

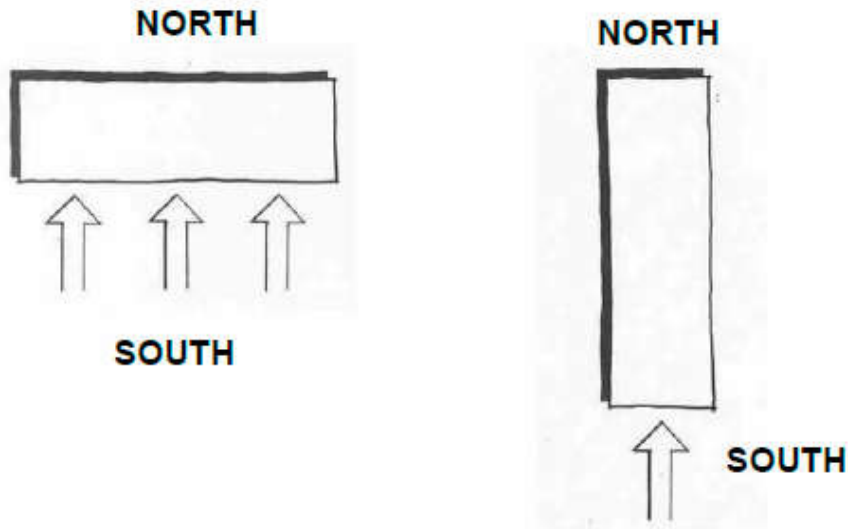

Figure 8  
Building orientation can maximize daylight exposure



Figure 9

Example of architectural shading devices

### **2.6.1 Considerations for orienting glazing:**

- Orient building to maximize north and south exposures.
- North facing windows provide the most even illumination.
- If orientation is off-axis from north and south, provide shading devices for south-east and south-west exposures.
- Provide architectural shading devices for south orientations.
- Provide manual shading devices for south orientations. Horizontal blinds best control the high angle light on southern exposures.
- Provide manual shading devices for east and west orientations. Vertical blinds best control the low angle light on east and west exposures.

**2.7 GLAZING CHARACTERISTICS.** Use selective glazing to optimize and tune glass based on its purpose and use (clerestory or vision). Clerestory glass may require high visibility transmittance without color distortion while minimizing infrared penetration.

**2.7.1 Considerations for glazing characteristics:**

- Maximize glazing transmittance (Tvis) for daylight glazing (.70 or greater) for clerestories and other daylight fenestrations.
- Although the visible transmittance selected depends on personal preference, typically, use Tvis values in the medium range for view windows (.40 or greater).
- Minimize infrared transmittance by specifying a moderate to low shading coefficient (SC) or low solar heat gain coefficient (SHGC) (50% or lower).
- Use high transmittance glazing greater than 60% to maximize daylight. Glazing should also have a high thermal resistance ratio in order to minimize heat gain.
- Use clear glazing. Do not use tinted or mirrored coatings.

Sample Glass Types	Total Daylight Transmittance %	Solar Heat Gain Coefficient
Clear Double Insulating Glass (1/8" thick)	81	0.75
Laminated Glass (1/2" clear)	85	0.72
HM 88/Clear	72	0.57
HM SC75/Clear	62	0.36
HM 55/Clear	47	0.30

Table 1  
Comparison of glass types

**2.8 QUANTITY OF GLAZING.** Through simple tools and modeling, glazing quantities can be optimized in order to provide maximum daylight potential while minimizing economic costs. Bring daylight in high through clerestories and top-lighting, yet provide view windows for occupant benefits. Also, bring daylight in from two directions if possible for balanced, uniform lighting.

**2.8.1** Toplighting optimization varies between 3% and 9% skylight to floor area ratio. The optimal amount of toplighting area factors in daylight contribution, cooling loads, and potential energy savings. In order to calculate toplighting area optimization, use a calculation program similar to “SkyCalc”. Sunny climates with a cooling load dominated environment will require less toplighting than cooler overcast climates.

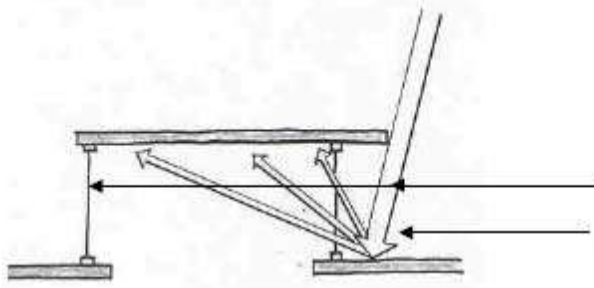

Vertical glass is shaded by overhang on south side.  
No overhang required on north side.  
Reflective roof directs light onto horizontal surface.

Roof Monitor

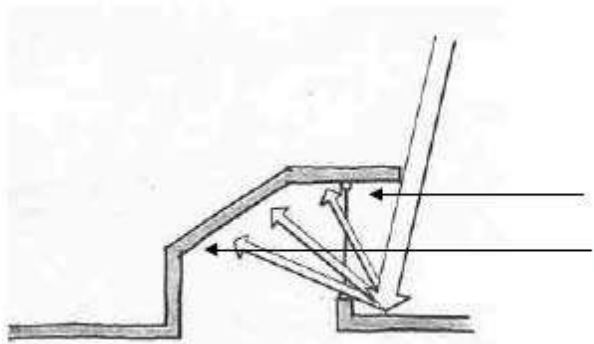

Vertical glass is shaded by overhang.  
High reflectance surfaces redirect and diffuse sunlight.  
Angled Clerestory

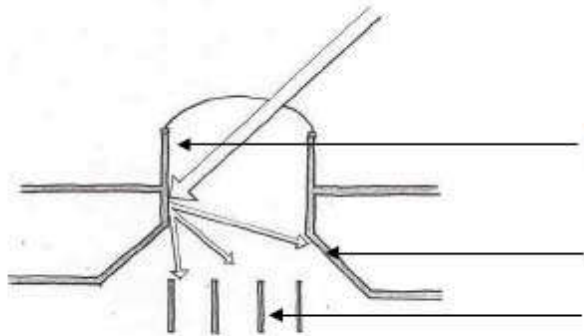

High reflectance surfaces redirect and diffuse sunlight.  
Splay directs light and reduces contrast.  
Vertical baffles block direct sunlight.  
Horizontal Skylights with Splay

Figure 10  
Diagrams of Toplighting Strategies





Figure 11  
Examples of Toplighting Applications



Figure 12  
Example of Clerestory Application



Figure 13  
Examples of Sidelighting Applications

### **2.8.2 CONSIDERATIONS FOR QUANTITY OF GLAZING:**

- Sidelighting windows should be located as high as possible since effective daylight penetration from windows is 1.5 times the height of the window.
- Use high continuous clerestories for the deepest daylight penetration and uniformity.
- In order to provide exterior views, provide glazing at eye level.
- Use view windows that have minimal wall area between windows. Avoid small windows located in large wall areas because of the uncomfortable contrast and glare that result.
- 0.09 m<sup>2</sup> (1 sq ft) of top lighting can provide illumination to about 10 times the area that Sidelighting provides yet does not provide the view.
- Space top lighting apertures approximately one and a half times the ceiling height for even illumination. Recess and splay (45° to 60°) skylights to minimize glare.
- Toplighting systems located at least 1.5 times the mounting height on center can provide even daylight distribution.
- Skylight area should be between 2% to 9% of the floor area depending on the climate optimization

**2.9 GLARE AND CONTRAST CONTROL.** Glare and excessive contrast occur when side and top lighting devices allow direct sunlight penetration. Quality daylighting allows skylight and only reflected sunlight to reach the task. Punched openings also can cause uncomfortable contrast ratios.



Figure 14  
Examples of Roof Shapes



Figure 15  
Example of Splayed Skylights

### **2.9.1 Considerations for controlling glare and contrast:**

- Provide external and internal shading as appropriate.
- Utilize top-lighting systems with vertical glazing to control direct radiation.

- If horizontal glazing is designed for top lighting systems, then provide splayed openings or translucent shielding below the skylight in order to minimize the contrast.
- Avoid punched windows; use continuous or mostly continuous side lighting.
- Use high reflectance surfaces for ceiling and walls (90% for ceilings and 60% for walls).
- Consider integrating use of automated window shading or dynamic glazing with the electric lighting control system to optimize the amount of daylight entering the space while minimizing the effects of solar heat gain and glare.

**2.10 ACTIVE DAYLIGHTING.** Active daylighting strategies and devices utilize a mechanical component to collect and distribute daylight. Such devices differ from the passive strategies that have previously been discussed which are stationary. The example shown in Figure 15 turns a series of reflectors as the sun moves throughout the day. These reflectors catch the direct sunlight and redirect it through the skylight.

**2.10.1** Such devices add extra initial cost and also pose additional maintenance issues. However, they also can make use of daylight for a longer period of time throughout the day. With tracking devices, effective daylighting can begin earlier in the morning and last later in the day than with stationary skylights. Careful evaluation of the lifecycle cost and the energy savings must be considered.





Figure 16  
Example of an Active Daylighting System that Tracks the Sun and  
Directs Daylight into the Building.



Figure 17  
Example of Solar-Adaptive Shading

**2.11 PHYSICAL MODELING.** Daylight levels depend on many factors such as window shapes, orientation, shading, and time of day. Therefore, physical models built to scale can provide information on light quality, shade, shadows, and actual light levels. By building the model with the actual proposed materials and orienting it with adjustments for latitude, season, and time of day, the light quality can be seen in the model. Such models inform the designer about quality issues including light patterns, shade, shadows, contrast, and penetration in the space. An illuminance meter inside the model will provide accurate predictions of expected light levels in the building.

**2.12 COMPUTER SIMULATION.** A wide range of software programs model the sun's path and its impact on building geometry in addition to how it affects heat gain and energy use. In using any of the software, the designer must be aware of its limitations and assumptions, as well as the variables under the user's control. These tools provide a prediction of how building components will behave throughout changing conditions. They do not provide actual light levels or energy use. The following web sites detail the features of some of these programs and their applications.

- US Department of Energy – Energy Efficiency and Renewable Energy Building Energy Software Tools Directory:  
[http://www.eere.energy.gov/buildings/tools\\_directory/](http://www.eere.energy.gov/buildings/tools_directory/)
- Whole Building Design Guide Energy Analysis Tools:  
<http://www.wbdg.org/resources/energyanalysis.php>